

FROSTLINE®



DUO H 30 WATER TAP



DUO H 30 WATER TAP

½" frost-proof water tap made from glass peened stainless steel. This water tap is particularly suitable for public parks and facilities, golf courses, camping sites and other areas with a need for reliable water supply all year round. The water tap is supplied complete with well.

The water tap is fitted with a self-emptying 3-way sliding valve, ensuring that the tap remains frost-proof, even at hard-freezing temperatures. The seals can be replaced without digging up the well. Unscrew the spindle housing from the top of the pipe stand, then pull up the spindle and replace the O-rings.

Is the product to be placed in an area with a high environmental impact, including sea fog, it is recommended to choose a special design i.e. an electro polished surface.

PRODUCT

Designation: ½" frost-proof water tap for outdoor installation
Tapping: ½" nipple pipe thread
Connection: ¾" nipple pipe thread

INSTALLATION DIMENSIONS

Tapping height: 760 mm
Tapping depth: 155 mm
Pipe stand height: 900 mm
Height of handle: 795 mm
Height of spout: 900 mm

PRODUCT DIMENSIONS

Overall height: 1,820 mm
Overall width: 166 mm
Well: D160 x 900 mm

SHIPPING

Dimensions, H-W-D: 1,840 x 200 x 300 mm
Weight: 10.5 kg complete with well

VALVE

FROSTLINE® self-emptying sliding valve
Capacity: 28-32 l/min. at 2-4 bar
O-rings: 8 x 3 mm NBR – shore 70

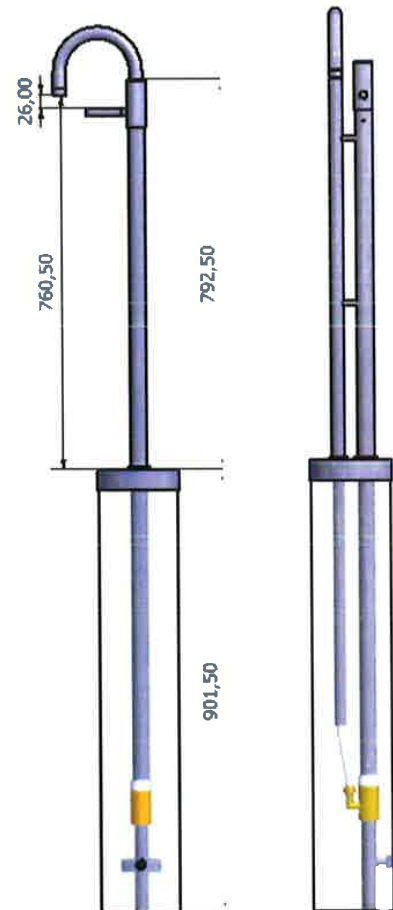

GDV-godkendelse nr.: 04/00116

OPERATION OF THE VALVE

The water tap is provided with a 3-way self-emptying sliding valve. When the water tap is not in use, the valve and riser pipe are emptied of water that might otherwise freeze. The water tap and thus the valve and riser pipe are frost-proof as long as the water supply line for the tap does not freeze.

MODELS		
F101	74.34.80.334	Duo H 30 Water Tap
F101-1	74.34.85.334	Duo H 30 w/automatic closing
F121	74.34.80.344	Duo H 9 Water Tap
F121-1	74.34.85.344	Duo H 9 w/automatic closing
ACCESSORIES		
F500	74.34.98.020	LUNA Rinse Bowl D250
F510	74.34.80.926	Duo Well Ring D60
F520	74.34.89.936	Blocking tube H
F530	74.34.89.916	Quick coupling - stainless steel
F921	74.34.89.004	Extension hose 300mm w/fitings



Duo w/Rinse Bowl and Well Ring

09.2008